

# Foster

stella

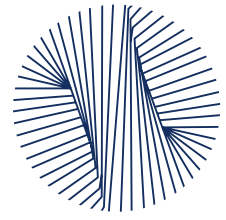

# Foster

stella

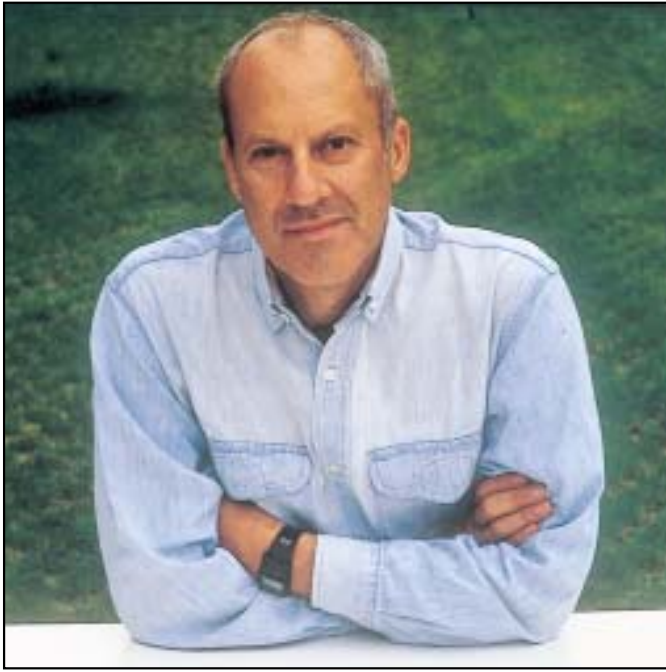

Norman Foster è nato a Manchester nel 1935. Ha studiato Architettura alle università di Manchester e di Yale. Lo studio Foster Associates viene fondato nel 1967; ora è conosciuto come Foster and Partners. Dall'inizio dell'attività lo studio ha ricevuto più di 220 premi e riconoscimenti e ha vinto 50 concorsi nazionali e internazionali. Recenti progetti includono il nuovo aeroporto internazionale di Hong Kong, la nuova sede del Parlamento Tedesco nel Reichstag a Berlino, la Great Court al British Museum e il nuovo Millennium Bridge a Londra. Norman Foster è stato insignito della Medaglia d'Oro Reale per l'Architettura dalla RIBA nel 1983, della Medaglia d'Oro dall'Accademia di Francia dell'Architettura nel 1991 e della Medaglia d'Oro dell'AIA nel 1994. Nel 1999 è diventato il ventunesimo Laureato del Premio Pritzker per l'Architettura e nello stesso anno ha avuto l'onore di essere insignito da Sua Maestà Britannica del titolo di Lord.



*Norman Foster was born in Manchester in 1935. He studied architecture at Manchester University School of Architecture and Yale University. Foster Associates was founded in 1967 and is now known as Foster and Partners. Since its inception the practice has received more than 220 awards and citations for excellence and has won 50 national and international competitions. Recent projects include Hong Kong International Airport, the new German Parliament, Reichstag, Berlin, the Great Court of the British Museum and the Millennium Bridge, London. Norman Foster was awarded the RIBA Royal Gold medal for Architecture in 1983, the Gold Medal of the French Academy of Architecture in 1991 and the AIA Gold Medal in 1994. In 1999 he became the 21st Pritzker Architecture Prize Laureate and in the same year he was honoured with a Life Peerage in the Queen's Birthday Honours List, Lord Foster of Thames Bank.*

# Foster

stella

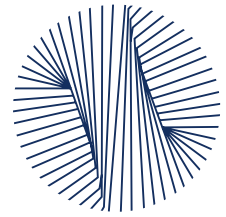

Nuova sede della Commerzbank - Francoforte  
New Commerzbank Headquarters - Frankfurt



Fin dagli inizi, trent'anni fa, lo Studio ha improntato la propria attività alla ricerca della qualità, nella convinzione che la qualità di ciò che ci circonda abbia un'influenza diretta sulla qualità della nostra vita sia nel posto di lavoro, sia nelle nostre case, sia negli spazi pubblici.

L'attenzione alla dimensione sociale deriva dalla consapevolezza che l'architettura è generata dai bisogni dell'uomo, che sono bisogni dello spirito oltre che materiali.

Questa filosofia e questi valori, che ispirano ogni nostro lavoro, non mutano a seconda della scala e delle dimensioni dei progetti. Il che spiega perchè per noi nessun dettaglio è di poca importanza e perchè prodighiamo la stessa cura anche al disegno di un mobile, di una maniglia, di un rubinetto. Sono tutti elementi, infatti, che contribuiscono a creare l'ambiente con cui veniamo in contatto ogni giorno della nostra vita: la qualità del design, della funzionalità, della fabbricazione di ognuno di essi ha rilevanza fondamentale.

*Since its inception, more than thirty years ago, the Studio has been driven by the pursuit of quality - a belief that the quality of our surroundings directly influences the quality of our lives, whether in the work place, at home or the wide variety of public spaces in between. This emphasis on the social dimension is an acknowledgment that architecture is generated by these needs of people and these are spiritual as well as material.*

*The philosophy and values, which inspire every project, are the same regardless of scale or size. This explains why no detail is too small in its importance for our studio and why the same amount of care and attention will be lavished on the design of a piece of furniture, a door handle or a tap. These, after all, are the elements of the environment that we physically touch every day of our lives and the quality of their design, their function and their manufacture is critical.*

*NyminmFolw*

# Foster

stella

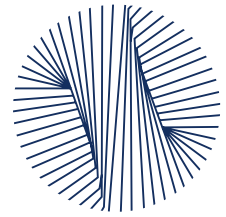

In questo progetto lo Studio Foster ha tenuto presenti le caratteristiche che, da sempre, distinguono i prodotti Stella:

- l'ergonomia - la maniglia di comando, di facilissima impugnabilità, asseconda perfettamente il movimento dell'organo di miscelazione consentendo una regolazione dolce e facile
- la sicurezza - la forma è compatta senza alcuna sporgenza acuminata
- le prestazioni - le forme consentono passaggi dell'acqua estremamente dolci con conseguente basso livello di rumorosità e buona erogazione
- la qualità - i materiali utilizzati anche per le parti in vista trasmettono l'usuale sensazione di massima qualità propria di tutti i prodotti Stella

Le finiture previste per la serie Foster sono cromo satinato e cromo lucido.

Sono eseguite su di un preventivo deposito di nichel di elevatissimo spessore che garantisce la massima qualità del risultato finale.

La qualità delle finiture Stella è diventata, nel tempo, un termine di paragone difficilmente eguagliabile.



*For this project the Foster Studio understood the features which have always distinguished Stella products.*

- *Human engineering - The control handle is easy to hold and follows the mixer movement to allow for smooth and easy control.*
- *Safety - The form is compact without any sharp protrusions.*
- *Performances - The water passes through the form very smoothly resulting in good supply and low noise.*
- *Quality - The high standard of manufacturing materials and finishes reflects the quality always associated with Stella products.*

*The finishes for the Foster Line are matt chrome and polished chrome.*

*The finishes are applied over a thick coating of nickel giving the highest quality of the final product.*

*The quality of Stella finishes has become, over time, a standard of comparison difficult to match.*

# Foster

stella



Il meccanismo di miscelazione, unico per tutti i gruppi della serie, frutto di un'esperienza ventennale ed esclusivo della Stella, è costituito da due sedi in ceramica alloggiato in un blocco di materiale antiaderente e insensibile ai depositi calcarei, e da un disco sempre in ceramica comandato da una leva impernata su una sfera.

La minima superficie d'attrito tra disco e sedi e il particolare disegno della maniglia consentono un movimento continuo e dolcissimo.

Il movimento del meccanismo di miscelazione consente di aprire, chiudere, regolare la quantità d'acqua e la sua temperatura con un solo, semplice movimento della maniglia con una dolcezza e facilità di manovra inimitabili.



*The mixing mechanism is common to all the products of the series. It is the result of two decades of Stella's experience.*

*It consists of two ceramic seats housed in a block of non-stick material, resistant to calcification, and a ceramic disk controlled by a hinged lever attached to a ball.*

*The combination of low frictional resistance and the design of the handle provides a smooth and controllable movement.*

*The mixing control makes opening, closing and the adjustment of temperature and waterflow simple, easy and enjoyable.*

# Foster

stella

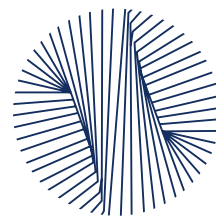

Foster 3224 - Miscelatore per lavabo monoforo in cromo satinato  
*Foster 3224 - Mixer for single-hole wash basin in matt chrome*

Foster 3224 in cromo lucido  
*Foster 3224 in polished chrome*

# Foster

stella



Foster 3267 - Miscelatore per vasca-doccia con deviatore automatico, modello esterno a parete in cromo satinato

*Foster 3267 - Exposed mixer for tub & shower with automatic diverter in matt chrome*

Foster 3267 in cromo lucido  
*Foster 3267 in polished chrome*

# Foster

stella

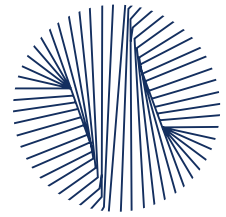

Foster 3292 - Miscelatore per doccia, modello da incasso in cromo satinato  
*Foster 3292 - Concealed shower mixer in matt chrome*

Foster 3292 in cromo lucido  
*Foster 3292 in polished chrome*

# Foster

stella

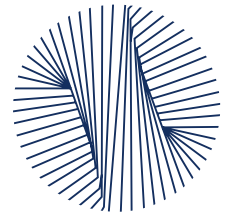

Foster 3230 - Miscelatore per lavello monoforo con bocca orientabile in cromo satinato

*Foster 3230 - Mixer with high swinging spout for single-hole sink in matt chrome*

Foster 3230 in cromo lucido  
*Foster 3230 in polished chrome*

# Foster

stella

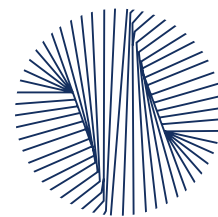

Foster 3604 - Miscelatore per bidet monoforo con rompigetto orientabile in cromo satinato

*Foster 3604 - Mixer with directional aerator for single-hole bidet in matt chrome*

Foster 3604 in cromo lucido

*Foster 3604 in polished chrome*

# Foster

stella

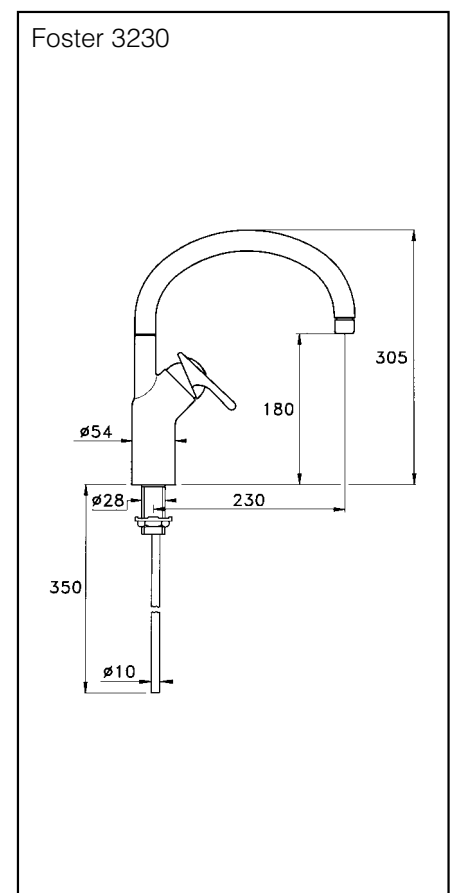
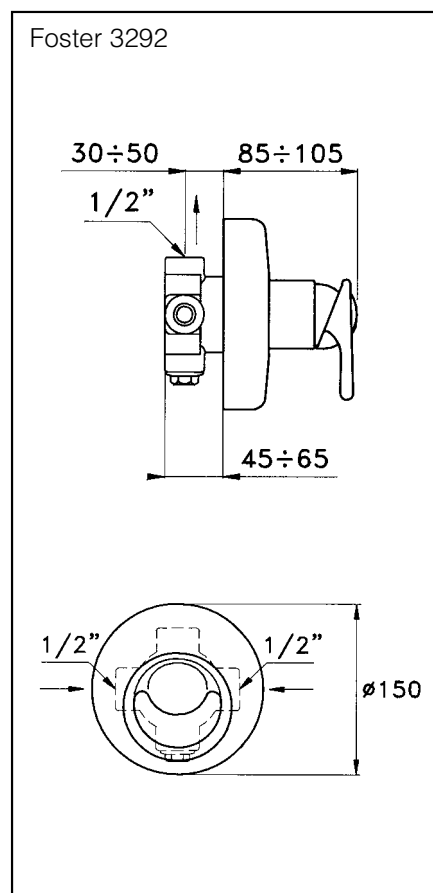
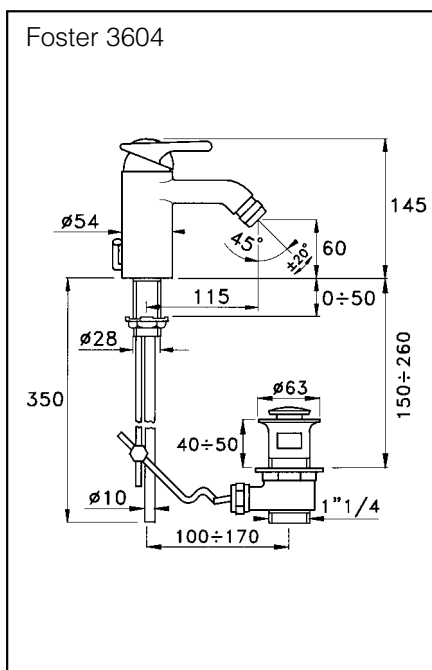
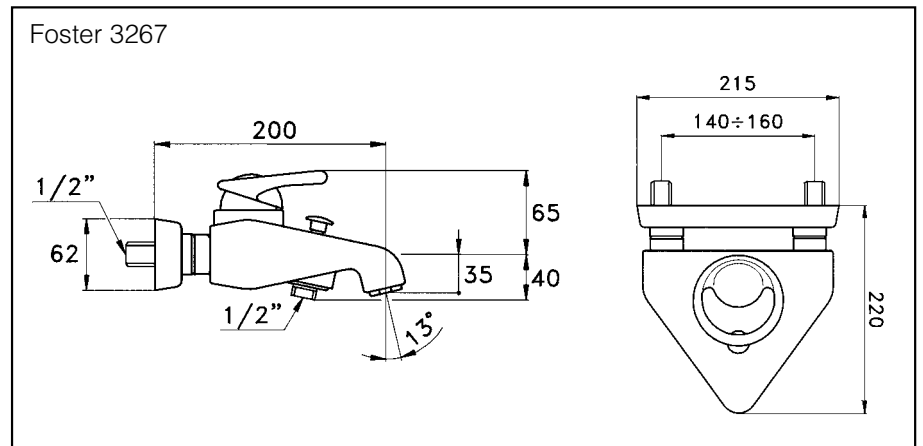
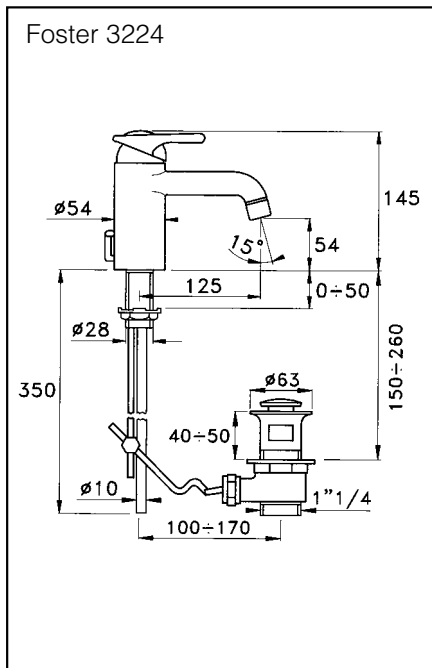
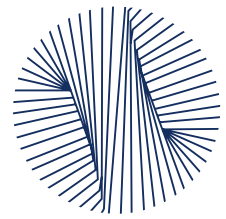

# Dal 1882

**stella**

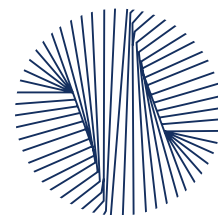

**Rubinerie Stella S.p.A.**

Sede produttiva e Uffici:

*Factory and Head office:*

Via Unità d'Italia, 1- 28100 Novara (Italy)

e-mail: [info@rubinetteriestella.it](mailto:info@rubinetteriestella.it)

Tel. 0321 47 33 51 r.a.

Fax 0321 47 42 31

Showroom:

Via San Maurilio, 19 - 20123 Milano (Italy)

Tel. 02 8699 5471

Fax 02 8699 2822

[www.rubinetteriestella.it](http://www.rubinetteriestella.it)